

Kit Overview Diagrams

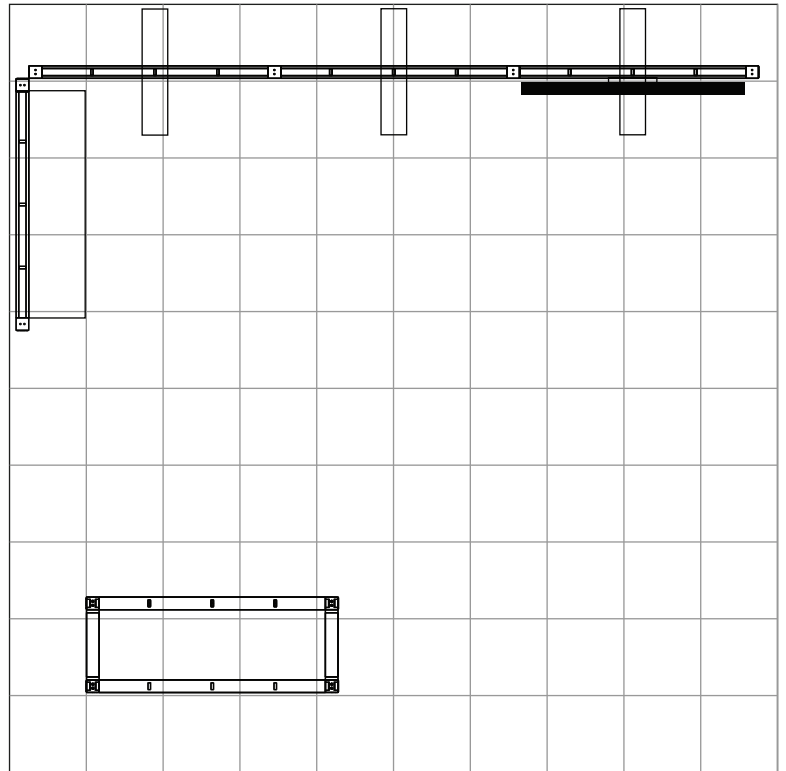

Note: This kit configuration may not require all your available components.

Graphics Diagram

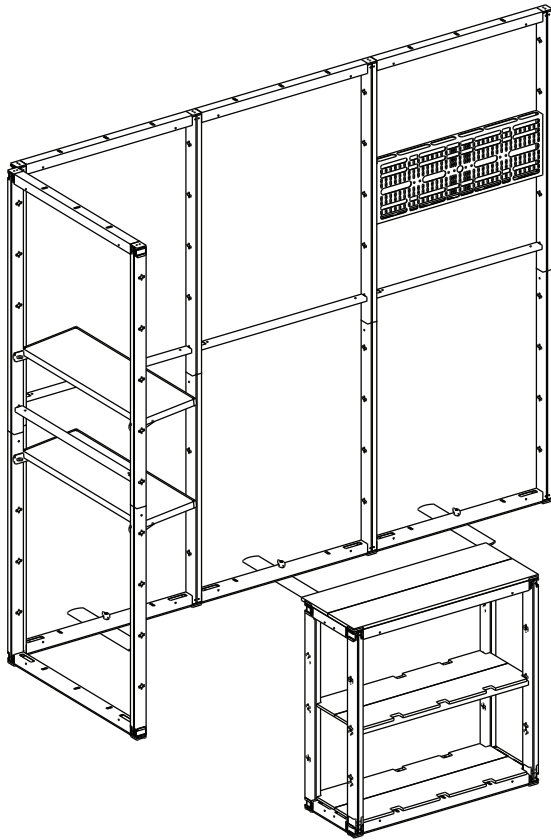
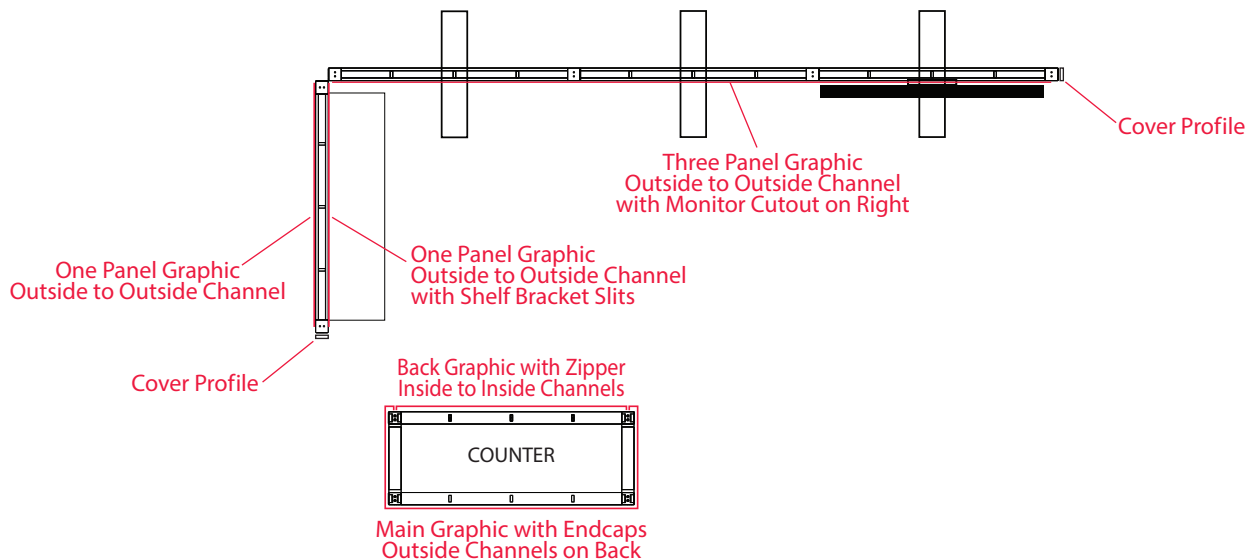

Backwall Assembly

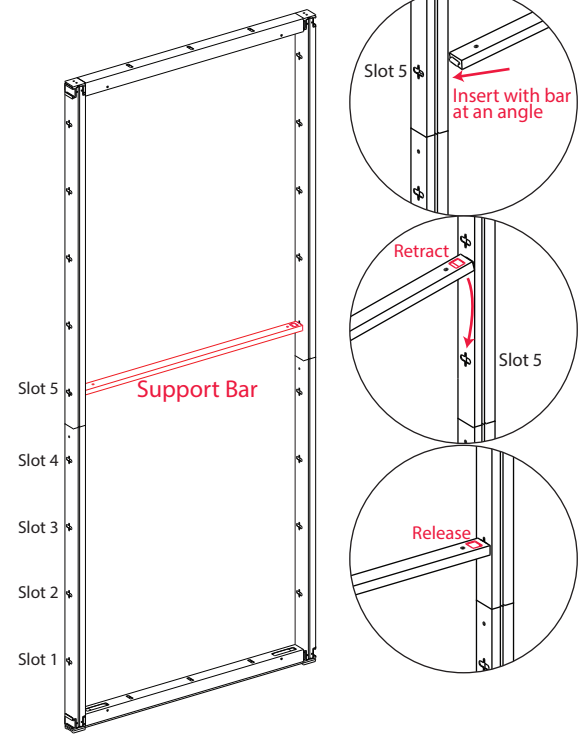
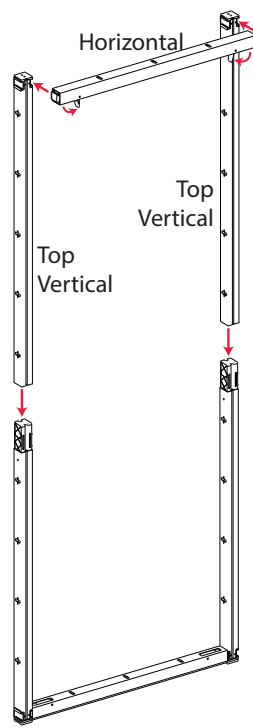
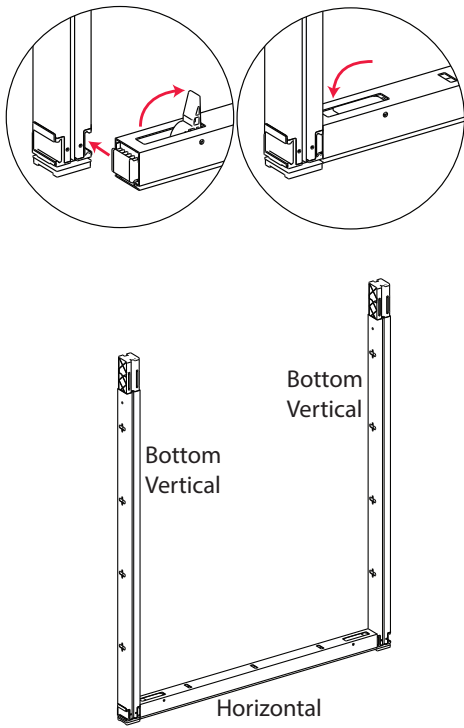

1. Assemble the first frame by connecting one horizontal bar between two bottom verticals, lift the lock levers, slide the parts together, and close the lock levers.

2. Slide the top vertical bars over the bottom vertical bars. Attach the top horizontal and lock the levers.

3. Attach the support bar by inserting the non-spring-loaded end into the 5th slot on the left with the other end of the bar lifted. Retract the spring lock and lower the right side until it lines up with the right slot. Release the spring lock.

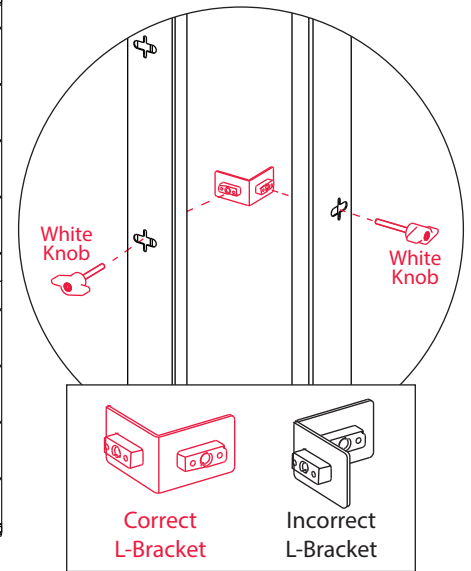
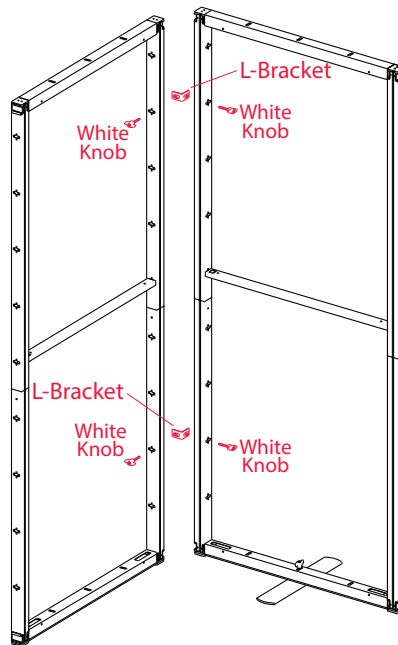
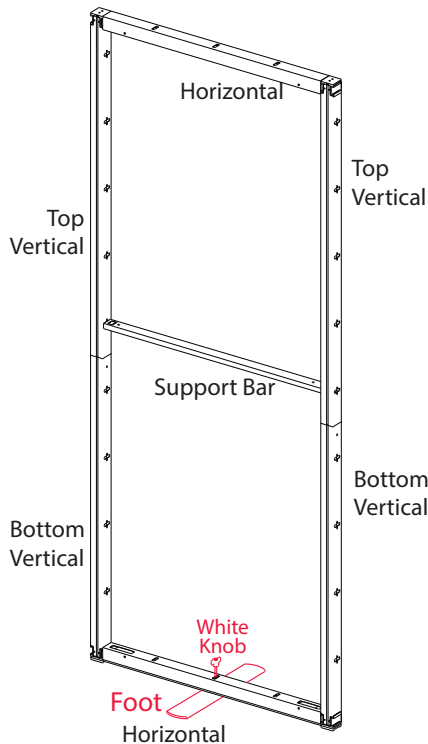

4. Repeat steps 1-3 to build a second frame.
5. Attach a foot to the frame and secure with a white knob.

6. Connect the two frames together with two standard L-brackets and four white knobs. This forms the back/left corner of the display.

10 Foot Kit P4-G-104 Assembly Instructions

Supporting Return Wall Assembly

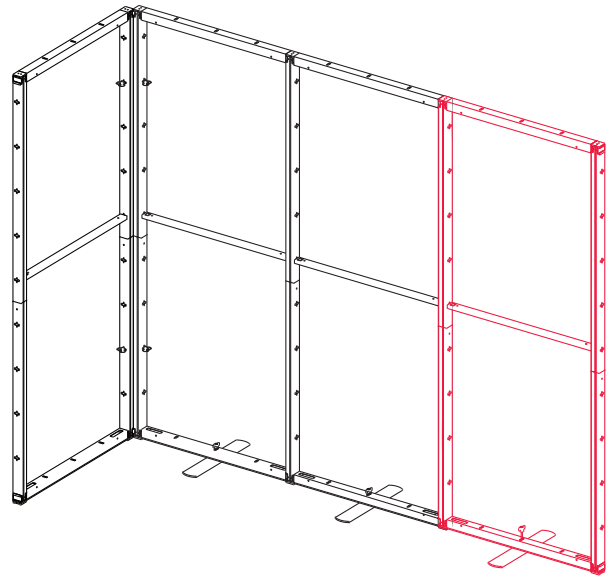
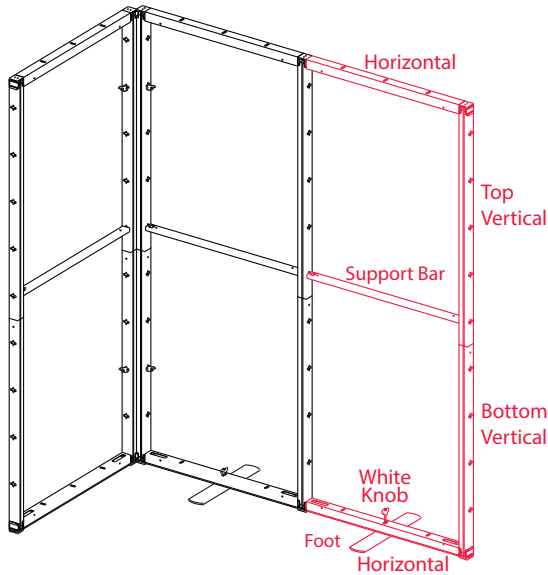

7. Extend the backwall by adding two more horizontals, foot with white knob, bottom vertical, top vertical, and support bar as seen above.

8. Repeat step 7 to extend the backwall one more frame.

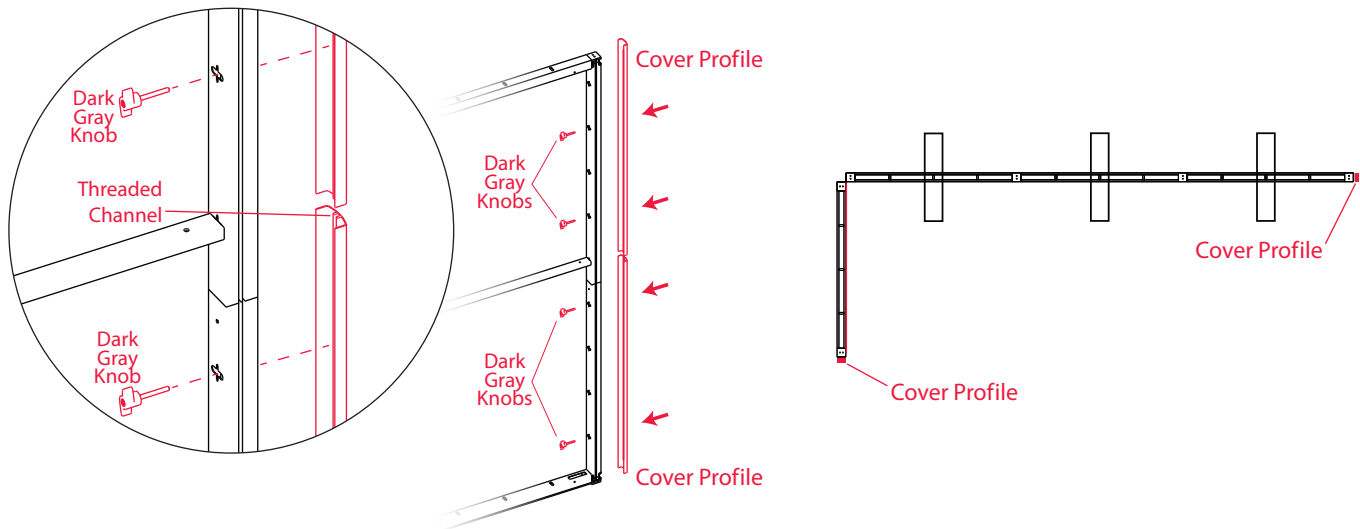

9. To cover the slots at the end of the frames, attach cover profiles with dark gray knobs as seen above. The knobs attach to the cover profile's threaded channel.

Monitor Mount Standard Installation

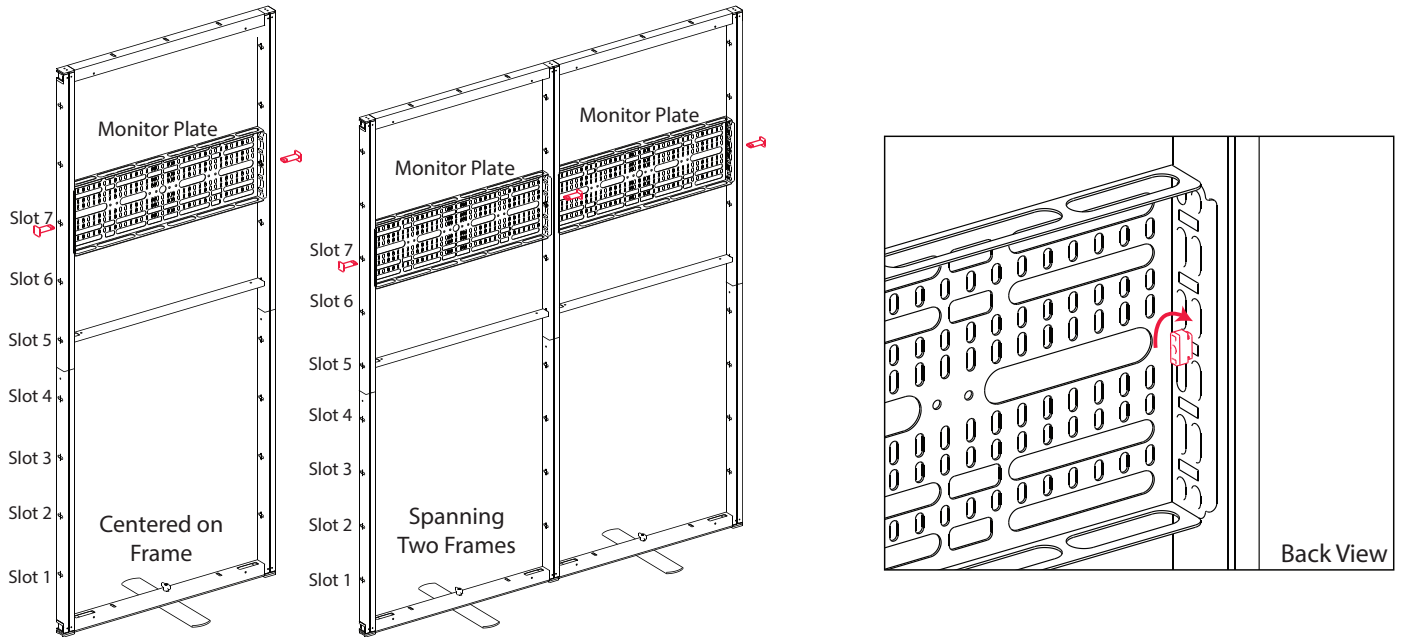

1. Attach the monitor plate to the frame(s) with monitor mount connectors (marked in red). Two plates may be attached on two adjacent frames as seen above. The plate will be flush to the front of the frame(s).
Note: Attaching a monitor mount on the front of a room requires different mounting hardware. See the room instructions for details.

2. Twist the ends of the connectors ninety degrees to lock them in place.

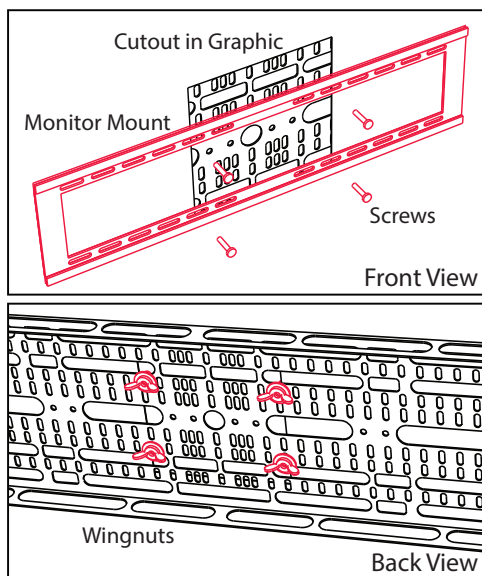

3. Install the fabric graphic with monitor mount cutout aligned over the monitor mount plate. See graphic installation instructions for details.
4. Attach the monitor mount onto the plate with screws. Secure with wingnuts on the back of the plate. When required, the mount may span across two plates as seen in step 1.

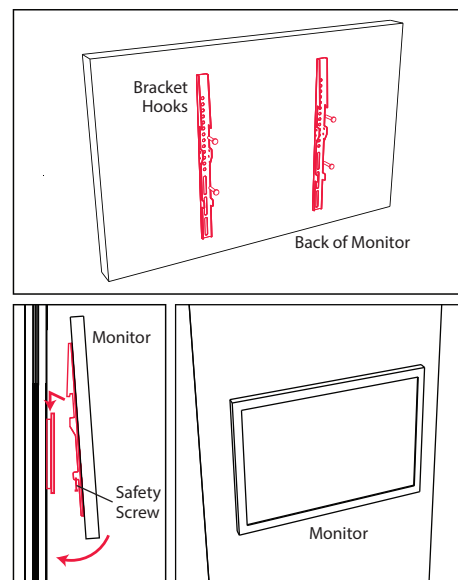

5. Attach the monitor mount hook bars onto the back of the monitor.
6. Hang the monitor hooks onto the monitor mount. This may require two people. Secure the safety screws on the hook bars.

Shelf Installation

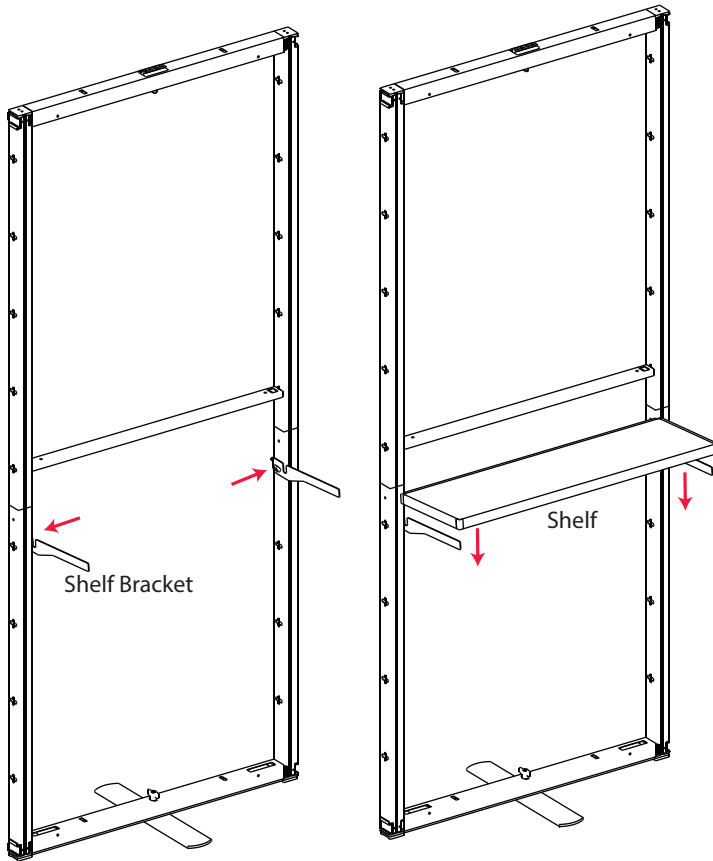

1. Attach two shelf brackets on the inside slots of the frame. Brackets will need to pass through slots in the fabric graphic (not shown above).
2. Set the shelf on top of the brackets.

Optional Shelf LED Installation

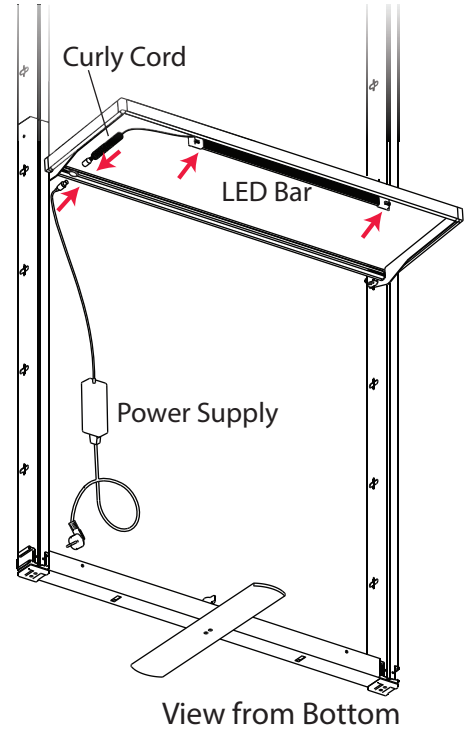

3. Install the optional LED bar to the bottom of the shelf. The bar snaps into the channel in the front, underside of the shelf. The curly cord connects to the power supply cord through the hole in the back edge of the shelf.

LED Stem Lights

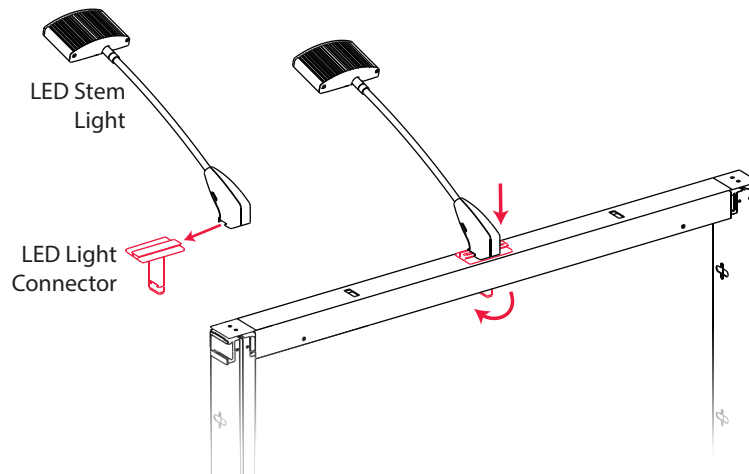

1. Attach the LED Stem Light to the LED Light connector (marked in red).
2. Insert the connector through the slot in the top of the frame. Twist the ends of the connectors ninety degrees to lock them in place.

10 Foot Kit P4-G-104 Assembly Instructions

Standard Counter Assembly

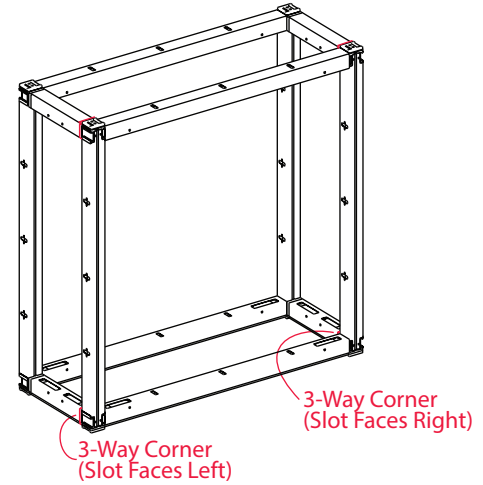
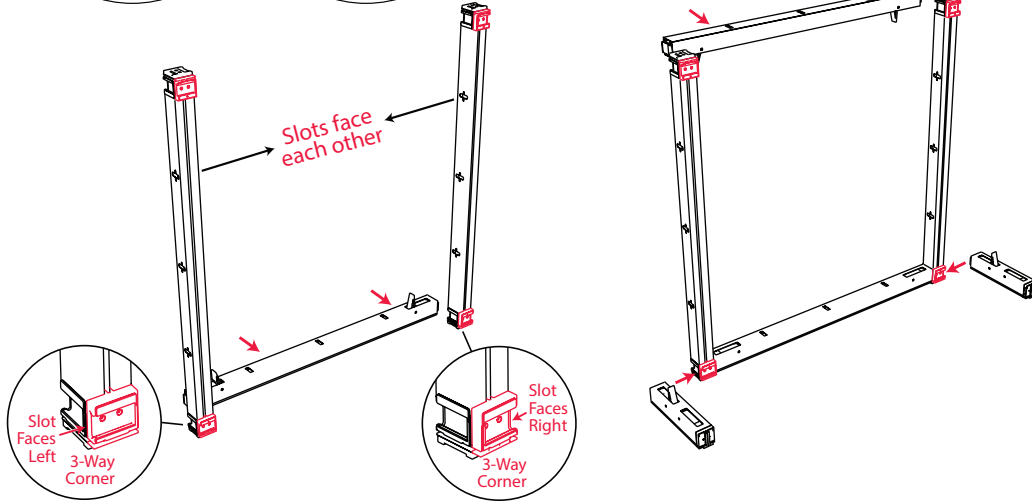
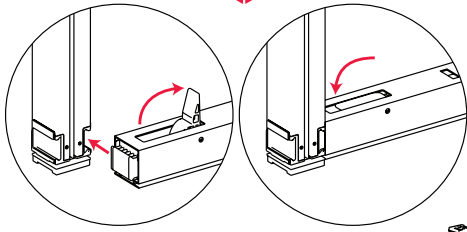

1. Locate two short vertical bars with 3-way corners on both ends. Attach the two together with a horizontal bar by lifting the lock levers and sliding the parts together.

2. Attach two short horizontals to the bottom 3-way corners. Attach a long horizontal to the top of the verticals. **Do not lock levers on the small horizontals until step 3.**

3. Add two more vertical bars, making sure that the short horizontal bars attach to their 3-way corners. Add the remaining horizontal bars to complete the frame. **Lock all levers.**

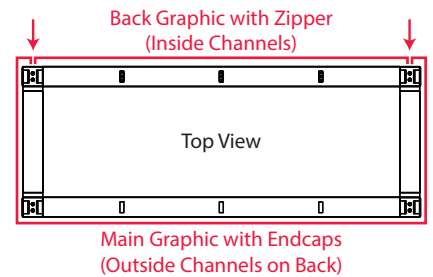
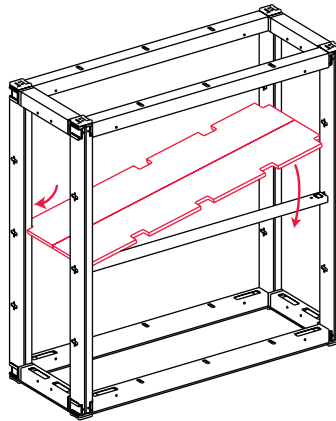
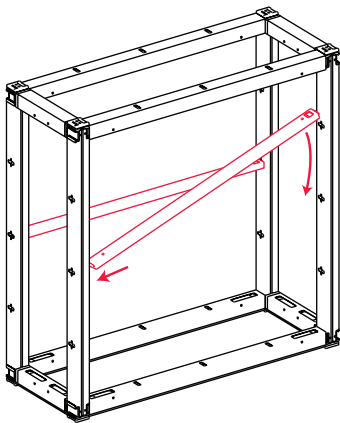

4. Attach two shelf support bars. Insert the non-spring-loaded end into the slot on the left with the other end of the bar lifted. Retract the spring lock and lower the right side until it lines up with the right slot. Release the spring lock.

5. Unfold and rest the shelf on the support bars.

6. Install the fabric graphics. See graphic installation instructions for details. It is most common for the front graphic to start on the back, wrap around the left side, front, right side, and end on the back.

7. Unfold and rest the countertop on top.

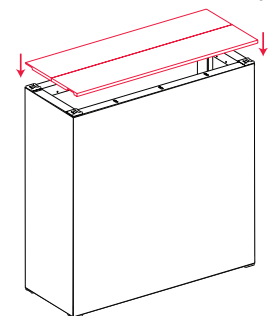
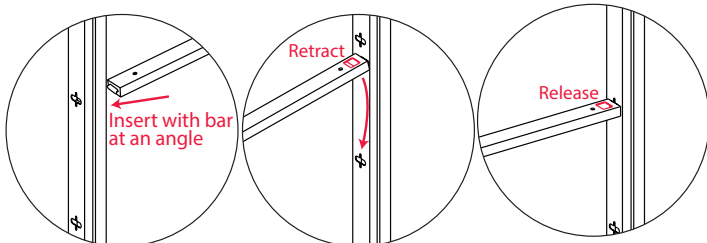

Graphic Installation

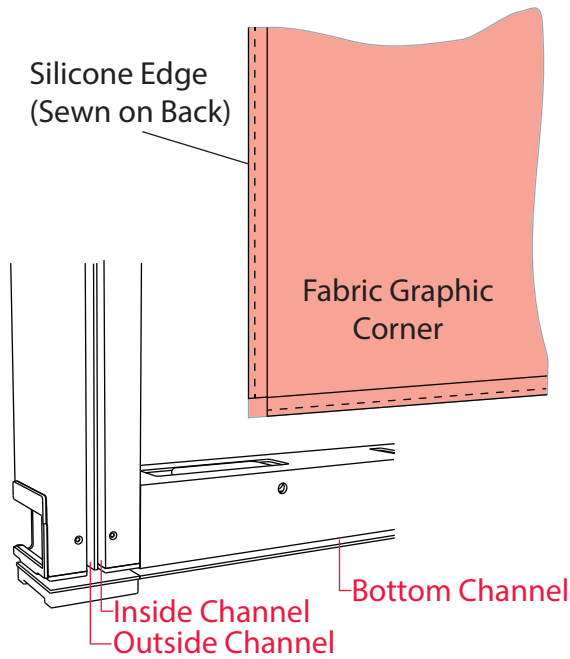

1. To install fabric graphics, turn the edge and tuck the silicone strip into the channel in the frame. The stitched edge goes in first.

Main backwall graphics go into the outside channels.

Do not stretch silicone edge graphic during installation.

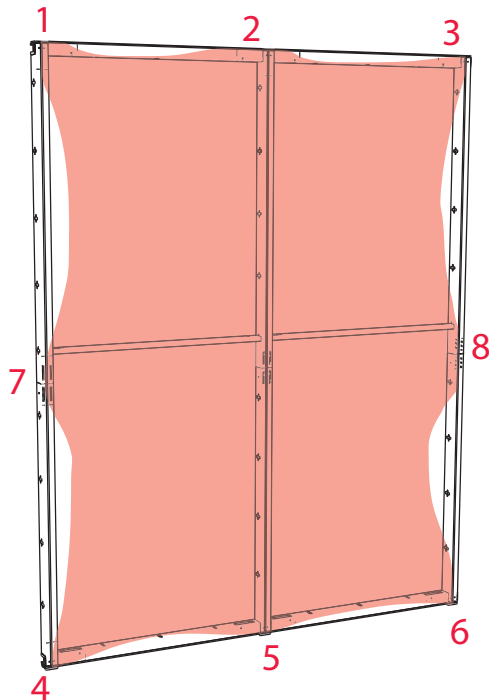

2. Starting in the top/left corner, tuck the graphic. Tuck periodically across the top and then the top/right corner. Repeat for the bottom edge. Tuck the center of the vertical edges.

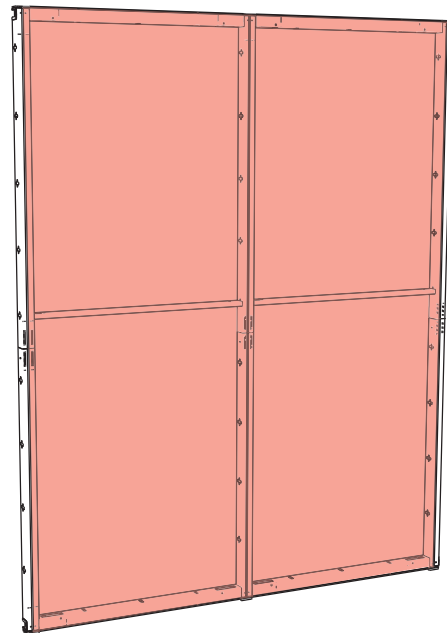

3. Tuck the remaining portion of the graphic to complete installation.

Some graphics may wrap around the side or back of a frame.

Crate Assembly

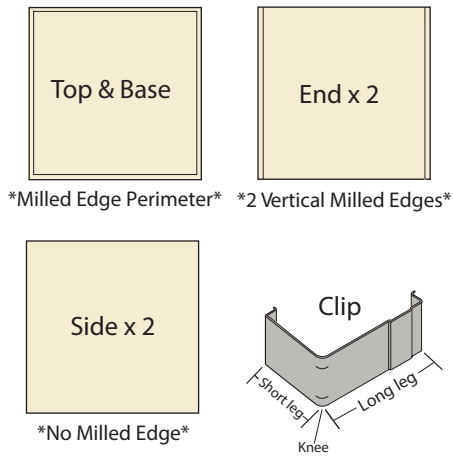

1. Identify boards and clip leg lengths.

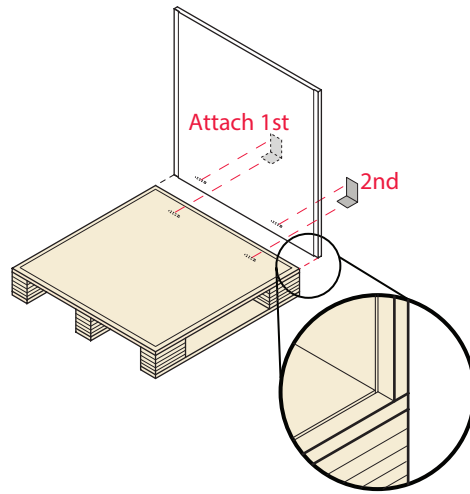

2. Attach end to base with clips.

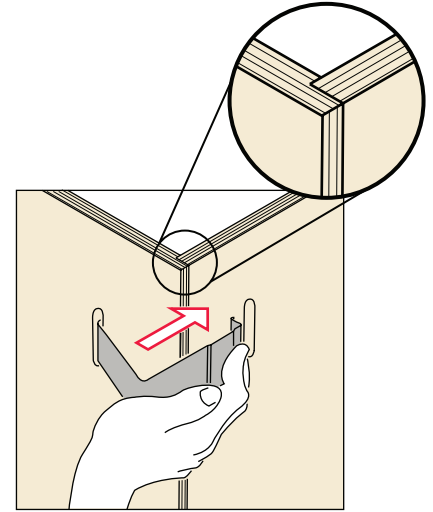

3. Attach clip so that the long leg spans across the edge of the overlapping board. Then, push the knee of the clip until it snaps into the slot.

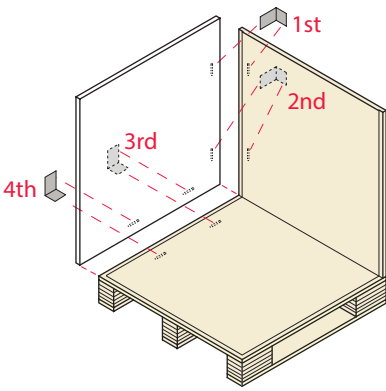

4. Attach side to end and base.

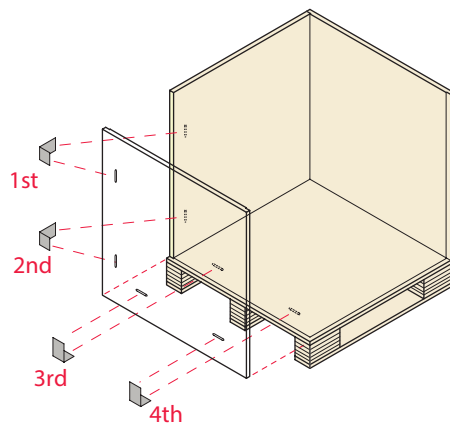

5. Attach end to side and base.

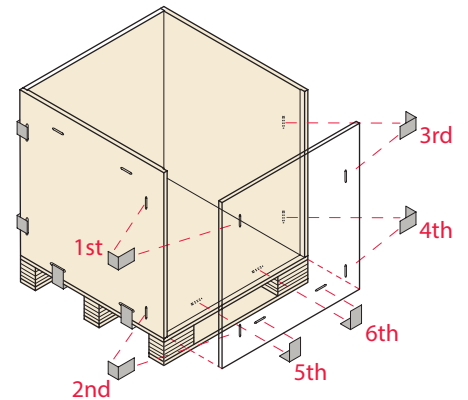

6. Attach side to both ends and base.

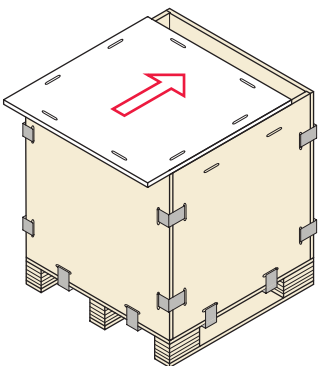

7. Fit top between the 2 sides and slide into place.

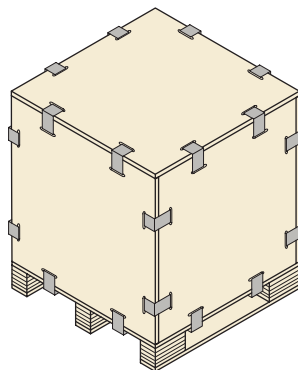

8. Be sure the top is fully seated, then attach with the remaining clips.

Disassembly

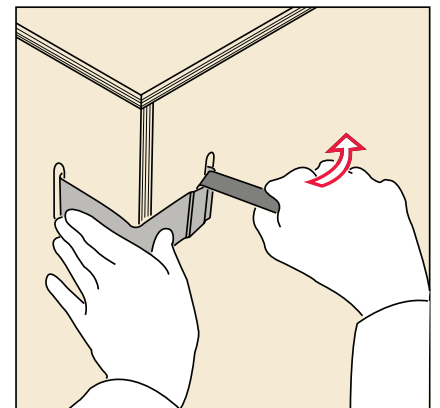

To remove clips, insert the removal tool into the raised pocket on the long leg of clip. Cover the clip with your hand and rotate the tool toward the center of the panel.



Always wear safety glasses when installing or removing clips.
Always cover the clip with your hand when removing clips.